

**ARMAPLATE**  
**CHALLENGER**

NOTE

All  
dimensions  
are for  
**GUIDANCE**  
only!

**APHK11**

**VIVARO**  
**TRAFIC**  
**TOLENTO**

**2014 - 2018**

**CAUTION**

Double-check to make sure that you have the right kit for the van you are working on BEFORE proceeding with your installation. If you are in any doubt, please ring 0845 838 0700.

## APHL60



**Not suitable for a glazed door!**

Read ALL instruction pages **before** starting!

### FITTING LOCKCASE

Fig.1

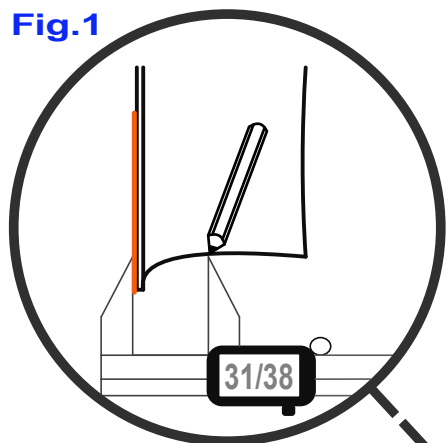

Protect paintwork by Applying **Masking Tape**

Fig.2

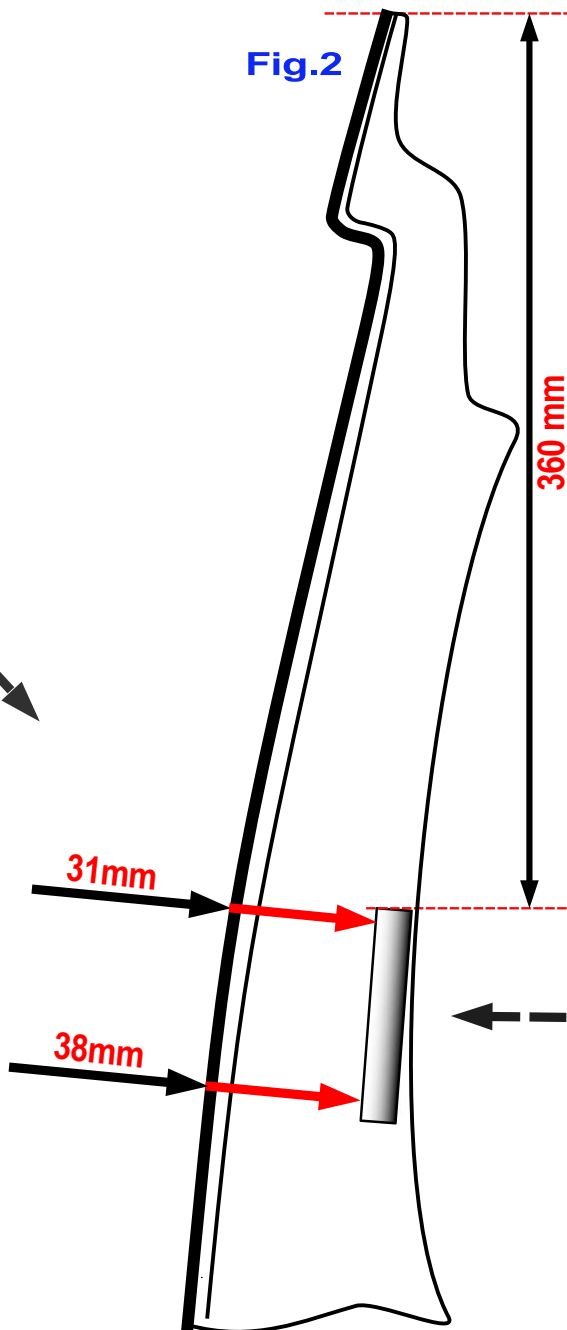
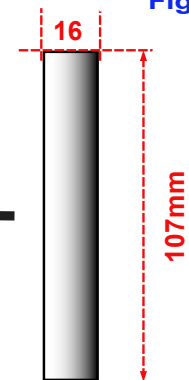

Fig.3



Lockcase Aperture Dimensions

**TIP:** Protect the side of the van with a piece of cardboard or plastic when cutting out LockCase aperture.

Nearside shown, mirror for offside door!

**NOTE: Treat all cut edges with rust-inhibitor!**

Armaplate UK Ltd have taken great care to ensure the accuracy of all the information contained within these data sheets and guides, but we accept no responsibility for any errors in text, drawings or other sources of information relating to the installation of our products. It is the responsibility of the person carrying out the installation to make sure that he/she has all the necessary equipment, tools, dimensions, instructions and knowledge before beginning the work. Under no circumstances should the fitter make any alterations or drill holes in the vehicle's bodywork without being completely sure that the security product supplied is the correct one for the Make, Model, Year, Configuration of the van, noting that some products for example will not fit a van if glass windows are present. It is HIGHLY RECOMMENDED that our security products are installed by Armaplate approved fitters who have had specific training in the correct methods. More information available on our website [www.arnaplate.com](http://www.arnaplate.com) TM

### SIDELOAD DOORS (Hi-Pos)

**CAUTION**

Double-check to make sure that you have the right kit for the van you are working on BEFORE proceeding with your installation. If you are in any doubt, please ring 0845 838 0700.

Read ALL instruction pages **before** starting!

# APHL60

## Not suitable for a glazed door!



## CYLINDER POSITION

Nearside shown, mirror for offside door!

Fig.5

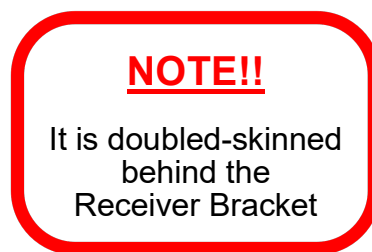
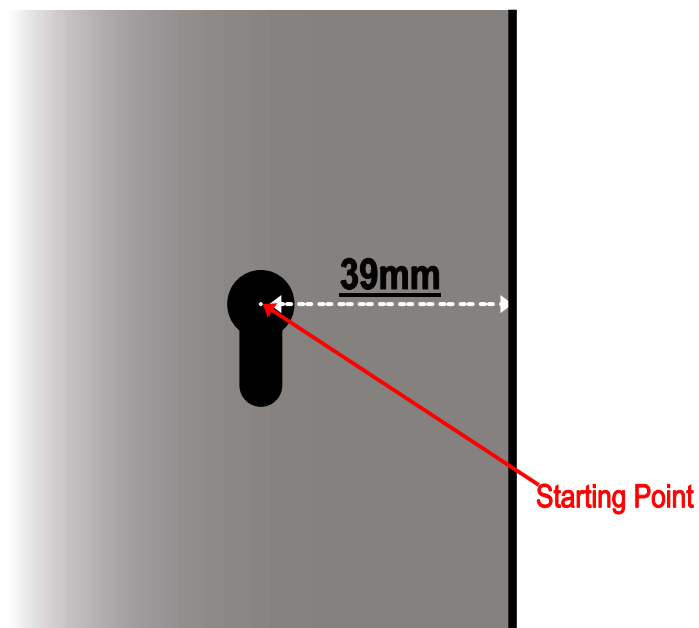

## FITTING RECEIVER BRACKET

With the door fully closed, assess the LockCase Hook by marking the **TIP** with a dab of paint.

Mark out the top of the Receiver aperture approx 3mm above that mark (see Fig.6).

Start cutting out the hole shape until the lock operates correctly, then check the plate-clearance.

Once satisfied that the lock operates properly, fix bracket with supplied 5mm CSK rivets.

Finally, fit the steel escutcheon plate around the lock cylinder using supplied 3.5mm rivets.

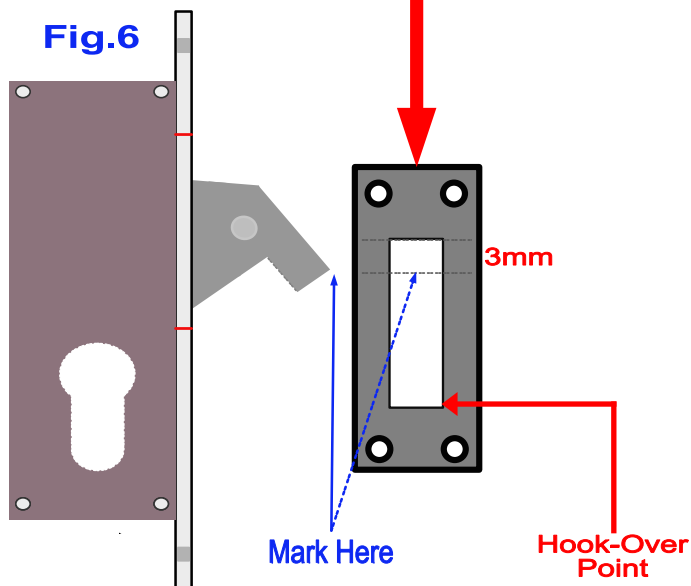

## **NOTE: Treat all cut edges with rust-inhibitor!**

Armaplate UK Ltd have taken great care to ensure the accuracy of all the information contained within these data sheets and guides, but we accept no responsibility for any errors in text, drawings or other sources of information relating to the installation of our products. It is the responsibility of the person carrying out the installation to make sure that he/she has all the necessary equipment, tools, dimensions, instructions and knowledge before beginning the work. Under no circumstances should the fitter make any alterations or drill holes in the vehicle's bodywork without being completely sure that the security product supplied is the correct one for the Make, Model, Year, Configuration of the van, noting that some products for example will not fit a van if glass windows are present. It is HIGHLY RECOMMENDED that our security products are installed by Armaplate approved fitters who have had specific training in the correct methods. More information available on our website [www.arnaplate.com](http://www.arnaplate.com) TM

## REAR BARN DOOR (Hi-Pos, Low-Roof)

### CAUTION

Double-check to make sure that you have the right kit for the van you are working on BEFORE proceeding with your installation. If you are in any doubt, please ring 0845 838 0700.

# APHL61



Read ALL instruction pages **before** starting!  
We recommend using a **step** to work more comfortably.

**Not suitable for a glazed door!**

## HI-LEVEL BRAKE LIGHT REMOVAL

- Remove the two Plastic Nuts from inside using a large flat-blade screwdriver (Fig.1)
- Carefully push the Plastic Clip inward from the left hand side of the light to remove (Fig.2)
- Unclip the Wiring Connector and unplug the light unit (Fig.3)
- Store the light unit away safely until you've completed the installation.
- Use Masking Tape to attach the cable to the outer doorskin so it's not in your way.

**Fig.1**

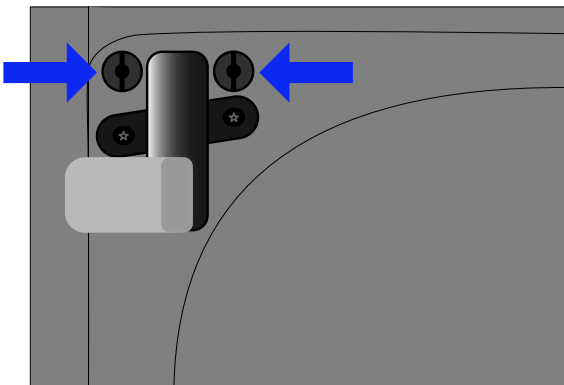

**Fig.2**

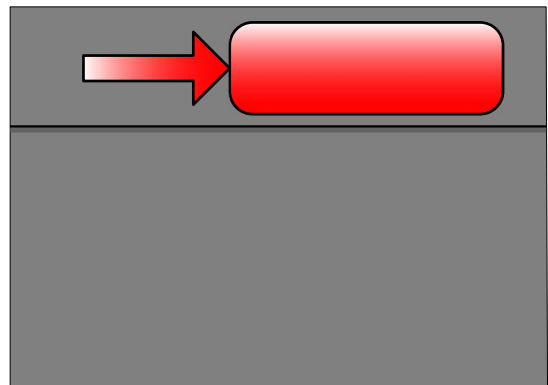

**Fig.3**

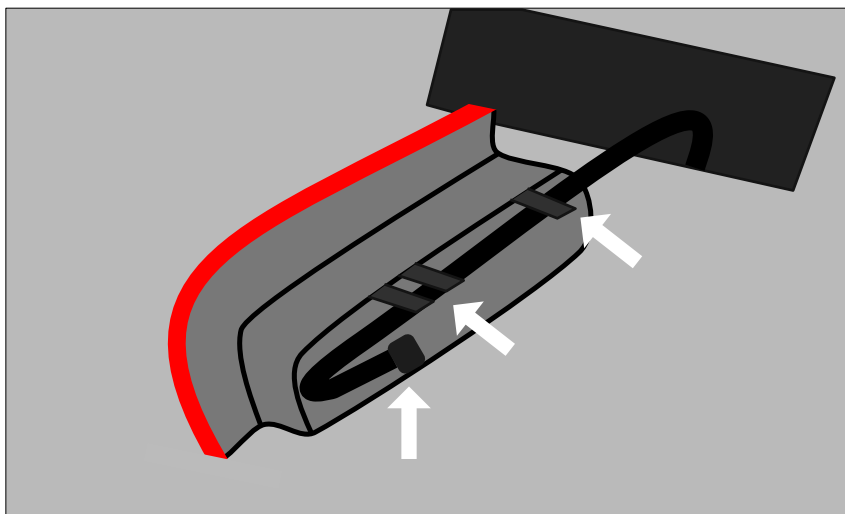

## **NOTE: Always treat any cut edges with rust-inhibitor!**

Armaplate UK Ltd have taken great care to ensure the accuracy of all the information contained within these data sheets and guides, but we accept no responsibility for any errors in text, drawings or other sources of information relating to the installation of our products. It is the responsibility of the person carrying out the installation to make sure that he/she has all the necessary equipment, tools, dimensions, instructions and knowledge before beginning the work. Under no circumstances should the fitter make any alterations or drill holes in the vehicle's bodywork without being completely sure that the security product supplied is the correct one for the Make, Model, Year, Configuration of the van, noting that some products for example will not fit a van if glass windows are present. It is HIGHLY RECOMMENDED that our security products are installed by Armaplate approved fitters who have had specific training in the correct methods. More information available on our website [www.arnaplate.com](http://www.arnaplate.com) TM

## REAR BARN DOOR (Hi-Pos, Low-Roof)

### CAUTION

Double-check to make sure that you have the right kit for the van you are working on **BEFORE** proceeding with your installation. If you are in any doubt, please ring 0845 838 0700.

# APHL61



Read ALL instruction pages **before** starting!  
 We recommend using a **step** to work more comfortably.

**Not suitable for a glazed door!**

## FITTING LOCKCASE

Fig.4

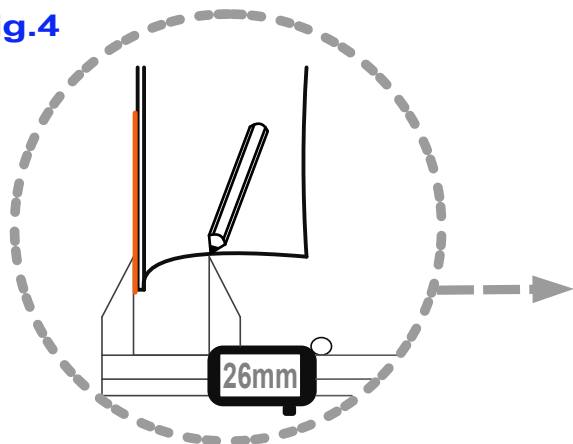

Protect paintwork by Applying **Masking Tape**

Fig.7

\* Fit this spacer between door-skin and Lockcase

**SPACER**



**\* WARNING!** Only use this Spacer if the gap between the door-skin and the LockCase forend is excessive!

Adjust the cylinder position to 66mm

No gasket required if spacer is fitted.

Fig.5

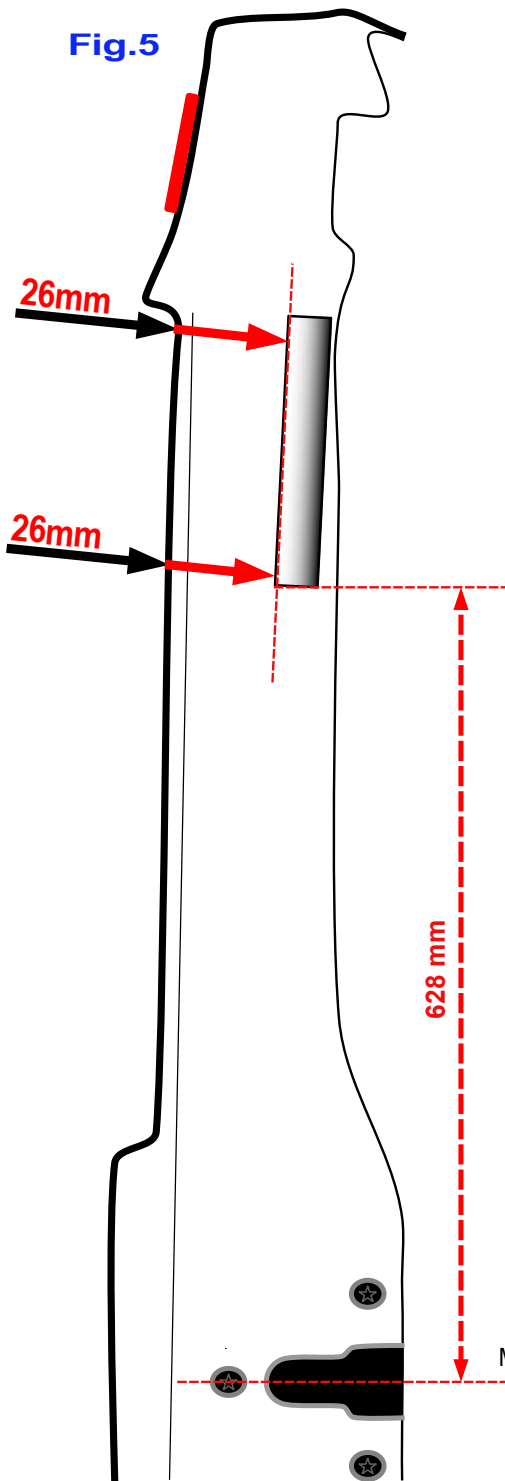
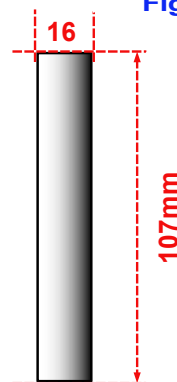

Fig.6



Lockcase Aperture Dimensions

Measure from **CENTRE** of Latch Bolt

## NOTE: Always treat any cut edges with rust-inhibitor!

Armaplate UK Ltd have taken great care to ensure the accuracy of all the information contained within these data sheets and guides, but we accept no responsibility for any errors in text, drawings or other sources of information relating to the installation of our products. It is the responsibility of the person carrying out the installation to make sure that he/she has all the necessary equipment, tools, dimensions, instructions and knowledge before beginning the work. Under no circumstances should the fitter make any alterations or drill holes in the vehicle's bodywork without being completely sure that the security product supplied is the correct one for the Make, Model, Year, Configuration of the van, noting that some products for example will not fit a van if glass windows are present. It is **HIGHLY RECOMMENDED** that our security products are installed by Armaplate approved fitters who have had specific training in the correct methods. More information available on our website [www.arnaplate.com](http://www.arnaplate.com) TM

REAR BARN DOOR (Hi-Pos, Low-Roof)

**CAUTION**

Double-check to make sure that you have the right kit for the van you are working on **BEFORE** proceeding with your installation. If you are in any doubt, please ring 0845 838 0700.

**APHL61**



Read ALL instruction pages **before** starting!  
 We recommend using a **step** to work more comfortably.

**Not suitable for a glazed door!**

**CYLINDER POSITION**

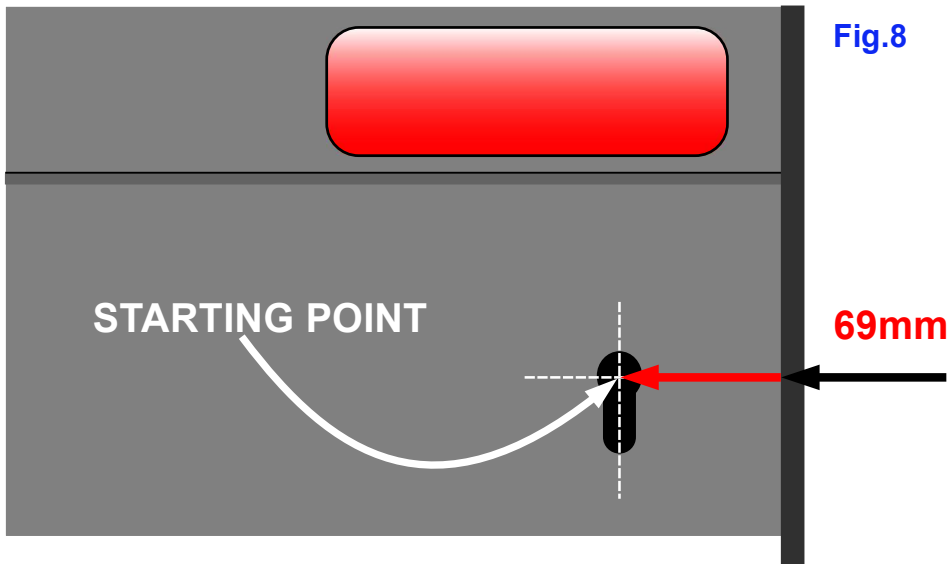

Fig.8

Fig.9



**FITTING RECEIVER BRACKET**

**DO NOT** secure the LockCase until the Receiver Bracket clearance has been checked!

With the Cylinder and the LockCase assembled in the door, close the doors and throw the Hook-Bolt.

From **INSIDE** the van, hold the Receiver Bracket in place on the opposite door and position the bottom of the cut-out so that the hook rests on it as shown in the image (Fig.9)

Mark the underside of the Receiver Bracket so that you can record the position you've settled on. (Note that if more clearance is required, adjust the LockCase Aperture).

When you are totally happy with the operation of the lock and the clearance, secure the LockCase and Bracket using the supplied 5mm rivets.

Fit the steel escutcheon plate over the lock cylinder with the supplied 3.5mm rivets.

Finally, refit the Brake Light unit in the top of the door.

**NOTE: Always treat any cut edges with rust-inhibitor!**

Armaplate UK Ltd have taken great care to ensure the accuracy of all the information contained within these data sheets and guides, but we accept no responsibility for any errors in text, drawings or other sources of information relating to the installation of our products. It is the responsibility of the person carrying out the installation to make sure that he/she has all the necessary equipment, tools, dimensions, instructions and knowledge before beginning the work. Under no circumstances should the fitter make any alterations or drill holes in the vehicle's bodywork without being completely sure that the security product supplied is the correct one for the Make, Model, Year, Configuration of the van, noting that some products for example will not fit a van if glass windows are present. It is **HIGHLY RECOMMENDED** that our security products are installed by Armaplate approved fitters who have had specific training in the correct methods. More information available on our website [www.arnaplate.com](http://www.arnaplate.com) TM

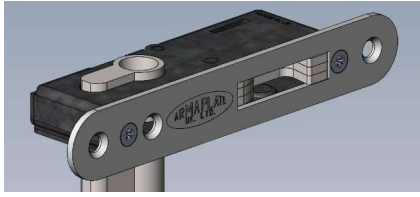

# How do I cut out the LockCase Aperture?

We always recommend that security products are installed by professional engineers who can guarantee that the highest levels of security and reliability are achieved, but if you wish to install the product yourself, you can use the Fitting Guide provided in the kit. Bear in mind that all dimensions are provided as nothing more than an approximate guide and it is the installers responsibility to determine the final fitting positions of each component.

When it comes to cutting out an aperture for the LockCase to fit in, there are a few different methods. People who install HookLocks on a daily basis will want to invest in specific tools such as nibblers, reciprocal saws, air-saws and die-grinders, etc, but if you are an owner-driver who will only be fitting a security device once, then you may choose to employ the most basic method of installation as shown below.

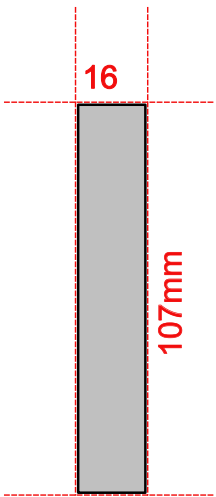

The first job is to refer to the main guide for the dimensions of the aperture cut-out and mark the area to be cut on your van.

Before you cut or drill *anything*, check and double-check that you have got the dimensions right. Measure twice, cut once!!!

If in any doubt, seek help before cutting.

EXAMPLE

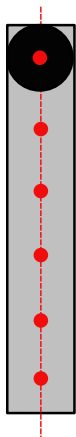
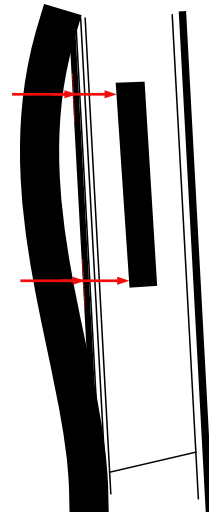

Mark out a centre-line and drill-points and then proceed to drill out a series of 16mm holes as shown on the right to remove the bulk of the metal.



Use a file to remove the excess metal to attain straight sides and sharp corners. You can employ a similar method for the *lock cylinder* aperture.

Make sure the edges are protected from corrosion by applying a liberal coats of rust-inhibitor.

**NOTE: Treat all cut edges with rust-inhibitor!**