

**ARMAPLATE**  
**CHALLENGER**

NOTE  
All  
dimensions  
are for  
**GUIDANCE**  
only!

**APHK09**

**MERC**

**VITO**

**2015 >**

**CAUTION**

Double-check to make sure that you have the right kit for the van you are working on BEFORE proceeding with your installation. If you are in any doubt, please ring 0845 838 0700.

This kit will fit the Mercedes Vito which was introduced around 2015. It will not fit the older Vitos.

# APHL43

Not suitable for a glazed door!



## FITTING THE LOCKCASE

### C-POST

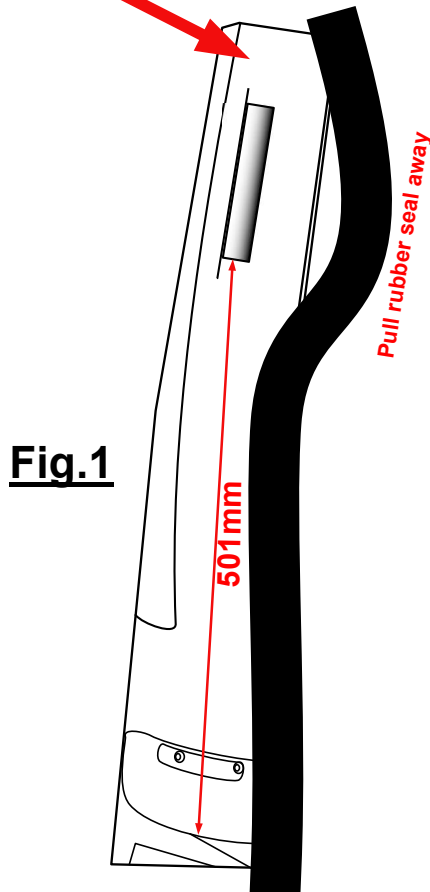

**Fig.1**

### Outer Door Skin

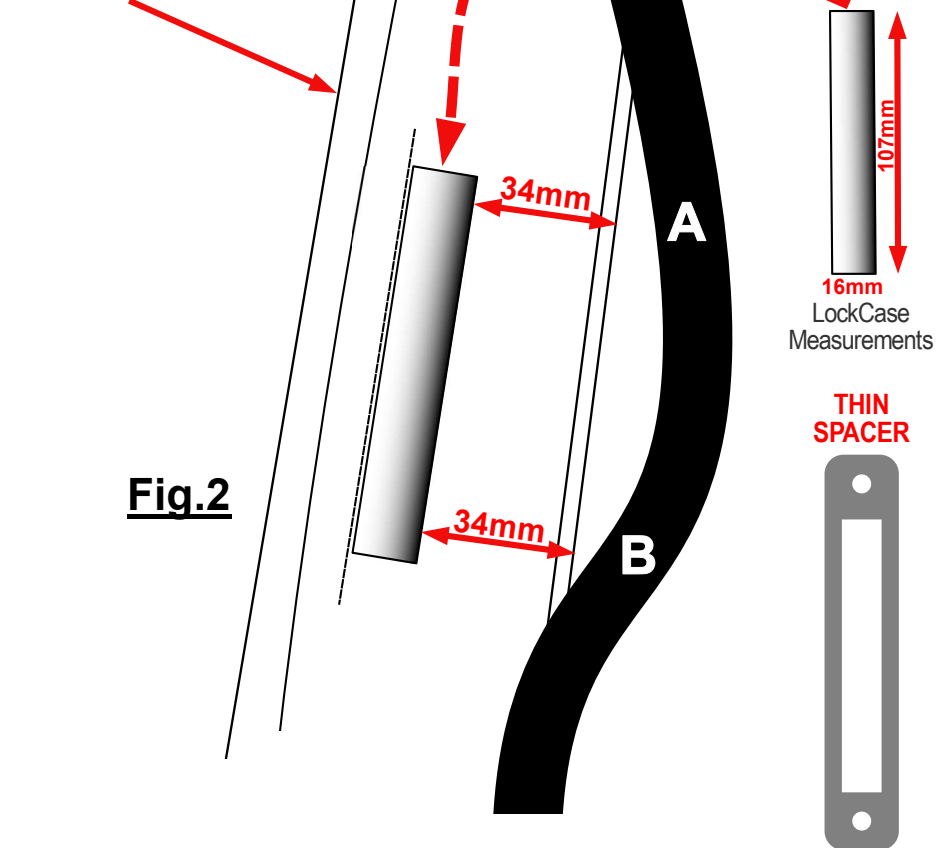

**Fig.2**

Measure 501mm up from the Door Runner Cover and mark the C-POST (see Fig.1)

Pull the rubber door seal away to allow you to take a measurement of 34mm (see Fig.2)

Set an adjustable set-square to 34mm and position the corner of the square to the outer lip where the door seal fits (see Fig.3) and mark the areas A and B.

Measure up 107mm from point B to point A.

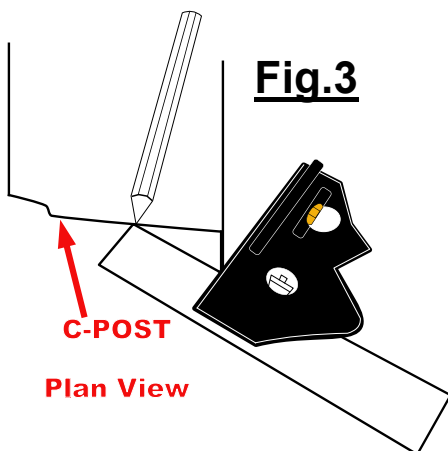

TIP : You may use the thin spacer provided to mark out the LockCase aperture.

## NOTE: Treat all cut edges with rust-inhibitor!

Armaplate UK Ltd have taken great care to ensure the accuracy of all the information contained within these data sheets and guides, but we accept no responsibility for any errors in text, drawings or other sources of information relating to the installation of our products. It is the responsibility of the person carrying out the installation to make sure that he/she has all the necessary equipment, tools, dimensions, instructions and knowledge before beginning the work. Under no circumstances should the fitter make any alterations or drill holes in the vehicle's bodywork without being completely sure that the security product supplied is the correct one for the Make, Model, Year, Configuration of the van, noting that some products for example will not fit a van if glass windows are present. It is HIGHLY RECOMMENDED that our security products are installed by Armaplate approved fitters who have had specific training in the correct methods. More information available on our website [www.arnaplate.com](http://www.arnaplate.com) TM

**CAUTION**

Double-check to make sure that you have the right kit for the van you are working on BEFORE proceeding with your installation. If you are in any doubt, please ring 0845 838 0700.

This kit will fit the Mercedes Vito which was introduced around 2015. It will not fit the older Vitos.

# APHL43

**Not suitable for a glazed door!**



### CYLINDER POSITION

**Fig.4**

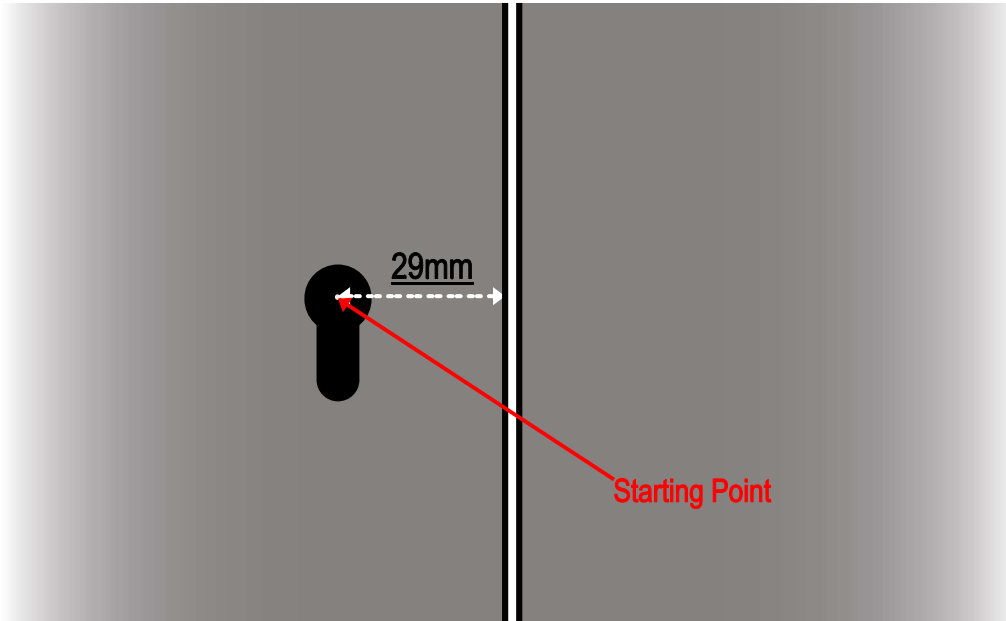

**With the door fully closed, assess LockCase hook position by marking the tip with a touch of paint.**

**Mark out the top of the plate aperture to approx 3mm above the paint-mark.**

**Gradually cut out the plate hole until the lock operates correctly and then once you're happy with the Plate clearance, secure with the supplied 5mm CSK rivets.**

**TIP: Self-tapping screws can be used to temporarily hold the receiver plate in situ.**

**NOTE : It is advisable to clamp the door-runner when working on the receiver plate hole and also to protect the side of the van next to the door with cardboard.**

**Fit escutcheon plate with 3.5mm rivets.**

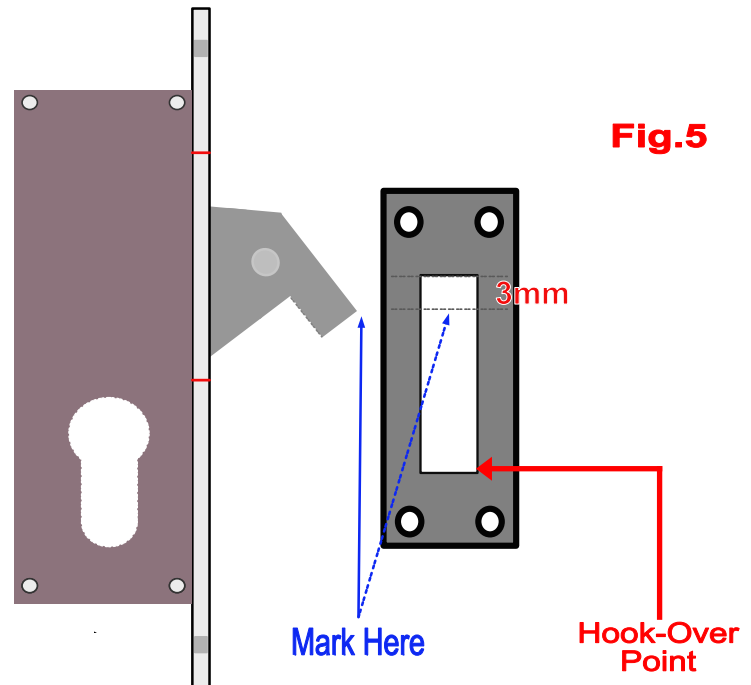

### **NOTE: Treat all cut edges with rust-inhibitor!**

Armaplate UK Ltd have taken great care to ensure the accuracy of all the information contained within these data sheets and guides, but we accept no responsibility for any errors in text, drawings or other sources of information relating to the installation of our products. It is the responsibility of the person carrying out the installation to make sure that he/she has all the necessary equipment, tools, dimensions, instructions and knowledge before beginning the work. Under no circumstances should the fitter make any alterations or drill holes in the vehicle's bodywork without being completely sure that the security product supplied is the correct one for the Make, Model, Year, Configuration of the van, noting that some products for example will not fit a van if glass windows are present. It is HIGHLY RECOMMENDED that our security products are installed by Armaplate approved fitters who have had specific training in the correct methods. More information available on our website [www.armaplate.com](http://www.armaplate.com) TM

**CAUTION**

Double-check to make sure that you have the right kit for the van you are working on BEFORE proceeding with your installation. If you are in any doubt, please ring 0845 838 0700.

This kit will fit the Mercedes Vito which was introduced around 2015. It will not fit the older Vitos.

# APHL44

**Not suitable for a glazed door!**



### FITTING THE LOCKCASE

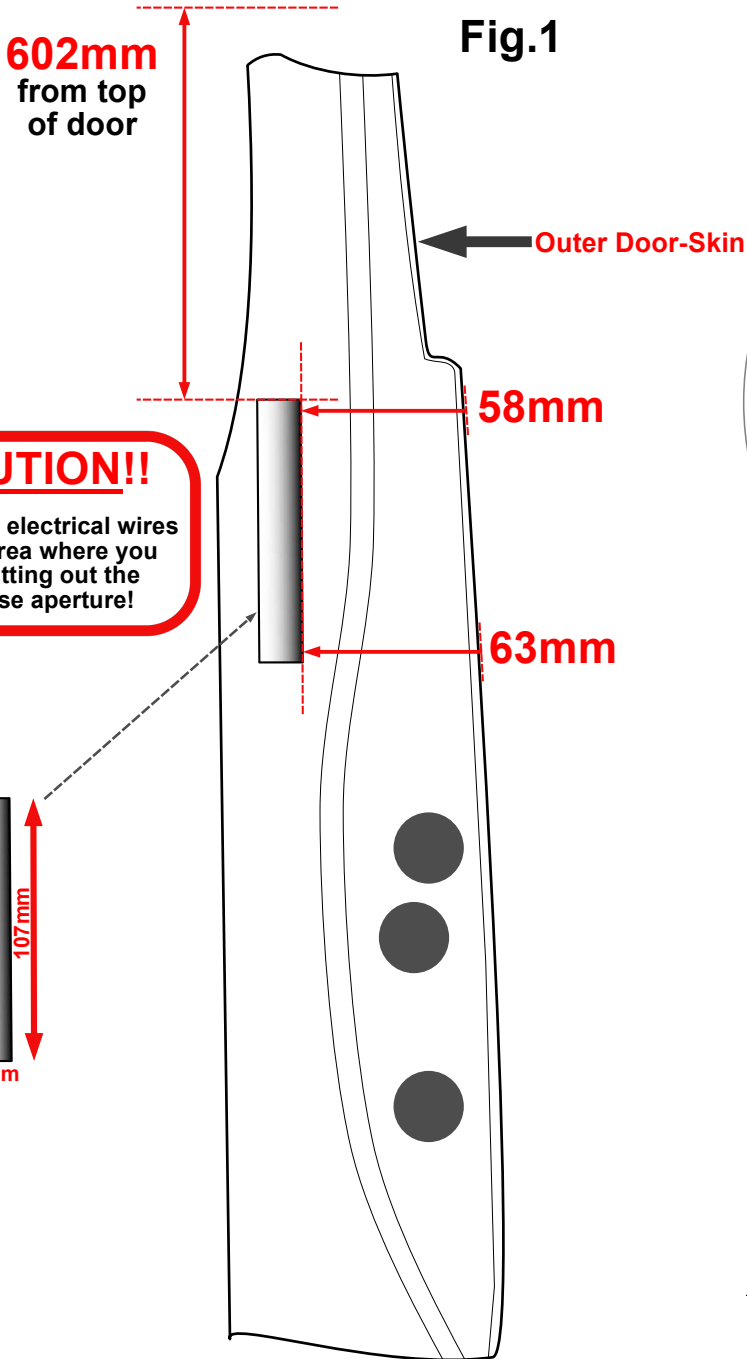

**CAUTION!!**  
There are electrical wires in the area where you are cutting out the lockcase aperture!



**Fig.1**

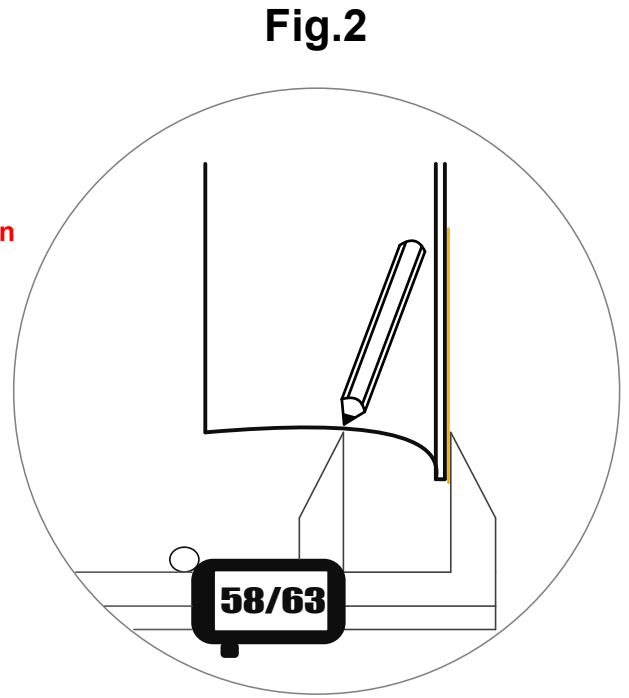

**Fig.2**

Protect paintwork by Applying Masking Tape

Use a Vernier Gauge to help mark out the dimensions of the aperture to be cut out

**NOTE!**

**DO NOT** secure the lockcase in position until the bracket position has been assessed.

**NOTE: Treat all cut edges with rust-inhibitor!**

Armaplate UK Ltd have taken great care to ensure the accuracy of all the information contained within these data sheets and guides, but we accept no responsibility for any errors in text, drawings or other sources of information relating to the installation of our products. It is the responsibility of the person carrying out the installation to make sure that he/she has all the necessary equipment, tools, dimensions, instructions and knowledge before beginning the work. Under no circumstances should the fitter make any alterations or drill holes in the vehicle's bodywork without being completely sure that the security product supplied is the correct one for the Make, Model, Year, Configuration of the van, noting that some products for example will not fit a van if glass windows are present. It is HIGHLY RECOMMENDED that our security products are installed by Armaplate approved fitters who have had specific training in the correct methods. More information available on our website [www.arnaplate.com](http://www.arnaplate.com) TM

**CAUTION**

Double-check to make sure that you have the right kit for the van you are working on **BEFORE** proceeding with your installation. If you are in any doubt, please ring 0845 838 0700.

This kit will fit the Mercedes Vito which was introduced around 2015. It will not fit the older Vitos.

# APHL44

**Not suitable for a glazed door!**

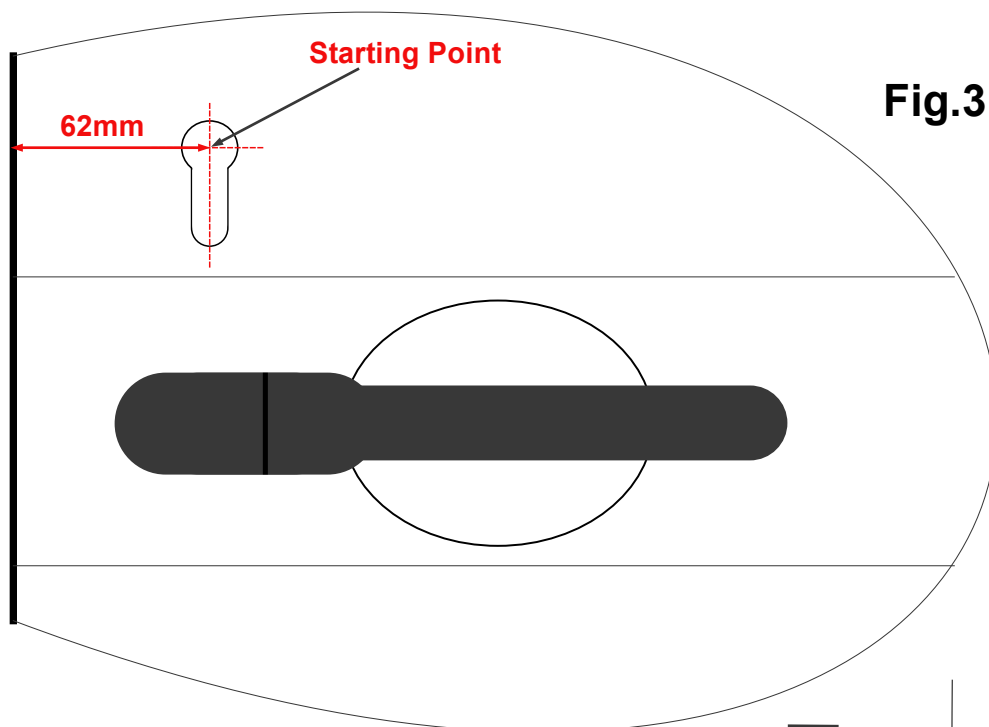

## CYLINDER POSITION

**Fig.3**

## FITTING RECEIVER BRACKET

**DO NOT secure the LockCase until the bracket-clearance has been checked.**

**Clearance can be checked from inside the van - hold the bracket in place with Masking Tape.**

**If more clearance is required, adjust the LockCase Aperture.**

**When the lock operates correctly, you can secure the bracket with the supplied 5mm Dome rivets.**

**Fit the Escutcheon Plate with the supplied 3.5mm rivets**

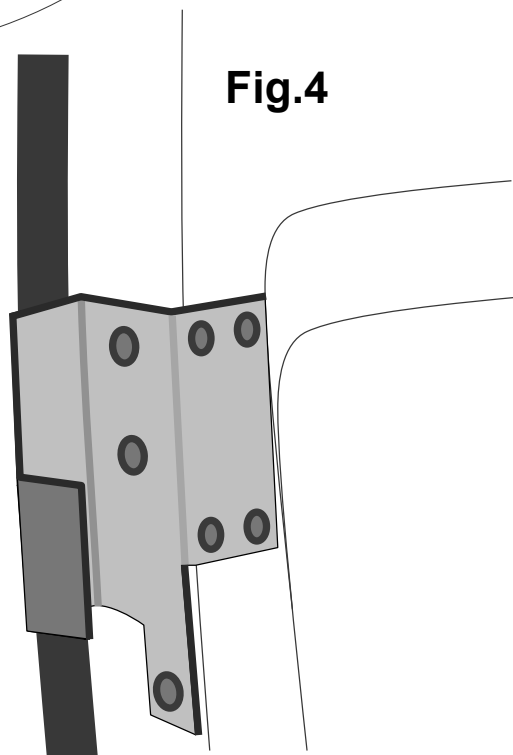
**Fig.4**

## **NOTE: Treat all cut edges with rust-inhibitor!**

Armaplate UK Ltd have taken great care to ensure the accuracy of all the information contained within these data sheets and guides, but we accept no responsibility for any errors in text, drawings or other sources of information relating to the installation of our products. It is the responsibility of the person carrying out the installation to make sure that he/she has all the necessary equipment, tools, dimensions, instructions and knowledge before beginning the work. Under no circumstances should the fitter make any alterations or drill holes in the vehicle's bodywork without being completely sure that the security product supplied is the correct one for the Make, Model, Year, Configuration of the van, noting that some products for example will not fit a van if glass windows are present. It is **HIGHLY RECOMMENDED** that our security products are installed by Armaplate approved fitters who have had specific training in the correct methods. More information available on our website [www.armaplate.com](http://www.armaplate.com) **TM**

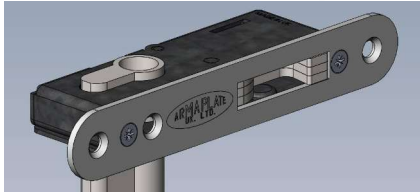

# How do I cut out the LockCase Aperture?

We always recommend that security products are installed by professional engineers who can guarantee that the highest levels of security and reliability are achieved, but if you wish to install the product yourself, you can use the Fitting Guide provided in the kit. Bear in mind that all dimensions are provided as nothing more than an approximate guide and it is the installers responsibility to determine the final fitting positions of each component.

When it comes to cutting out an aperture for the LockCase to fit in, there are a few different methods. People who install HookLocks on a daily basis will want to invest in specific tools such as nibblers, reciprocal saws, air-saws and die-grinders, etc, but if you are an owner-driver who will only be fitting a security device once, then you may choose to employ the most basic method of installation as shown below.

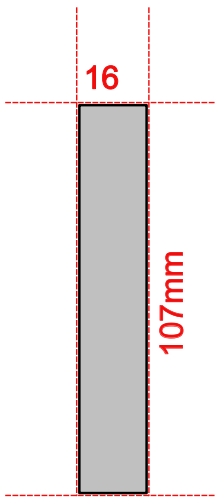

The first job is to refer to the main guide for the dimensions of the aperture cut-out and mark the area to be cut on your van.

Before you cut or drill *anything*, check and double-check that you have got the dimensions right. Measure twice, cut once!!!

If in any doubt, seek help before cutting.

EXAMPLE

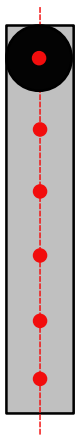
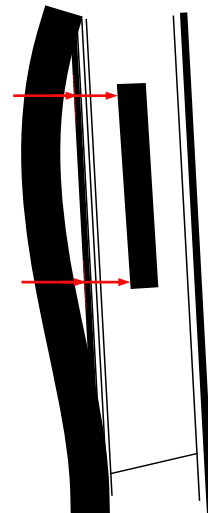

Mark out a centre-line and drill-points and then proceed to drill out a series of 16mm holes as shown on the right to remove the bulk of the metal.



Use a file to remove the excess metal to attain straight sides and sharp corners. You can employ a similar method for the *lock cylinder* aperture.

Make sure the edges are protected from corrosion by applying a liberal coats of rust-inhibitor.

**NOTE: Treat all cut edges with rust-inhibitor!**