

ARMAPLATE
CHALLENGER

NOTE

All
dimensions
are for
GUIDANCE
only!

APHK06

DISPATCH

EXPERT

PROACE

2016 >

VAUXHALL
VIVARO
2019 ONWARD

CAUTION

Double-check to make sure that you have the right kit for the van you are working on BEFORE proceeding with your installation. If you are in any doubt, please ring 0845 838 0700.

This kit will also fit a Peugeot Expert and Toyota ProAce of the same year, and the updated Vauxhall Vivaro from 2019 onwards.

APHL27



Not suitable for a glazed door!

FITTING THE LOCKCASE

Fig.1

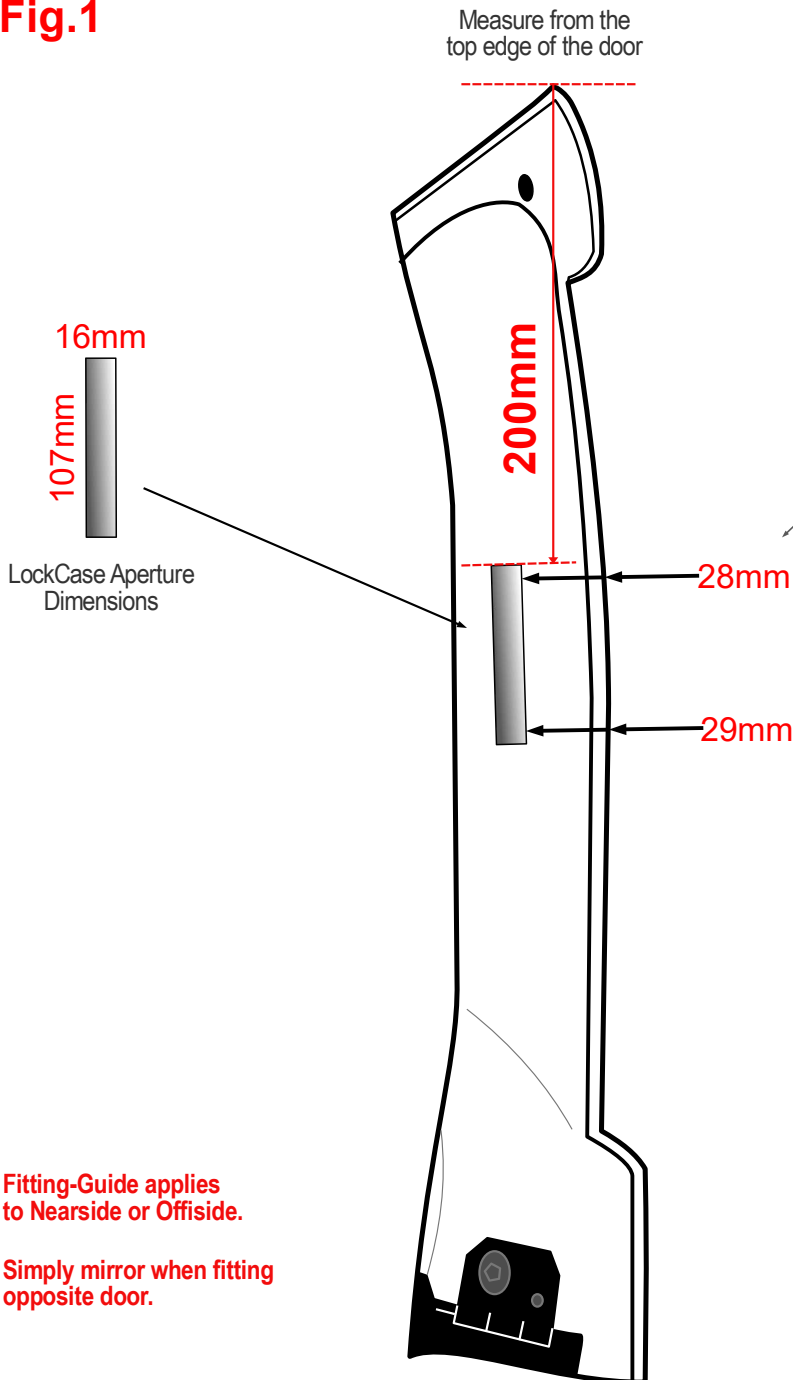

Fitting-Guide applies to Nearside or Offside.

Simply mirror when fitting opposite door.

Fig.2

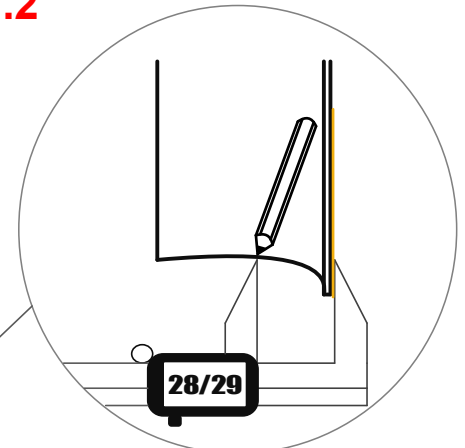

Protect paintwork by Applying Masking Tape
Use a Vernier Gauge to help mark out the dimensions of the aperture to be cut out

THIN SPACER



Slide the thin spacer over the Lockcase body to mate up to the rear of the frontplate.

NOTE: Treat all cut edges with rust-inhibitor!

Armaplate UK Ltd have taken great care to ensure the accuracy of all the information contained within these data sheets and guides, but we accept no responsibility for any errors in text, drawings or other sources of information relating to the installation of our products. It is the responsibility of the person carrying out the installation to make sure that he/she has all the necessary equipment, tools, dimensions, instructions and knowledge before beginning the work. Under no circumstances should the fitter make any alterations or drill holes in the vehicle's bodywork without being completely sure that the security product supplied is the correct one for the Make, Model, Year, Configuration of the van, noting that some products for example will not fit a van if glass windows are present. It is HIGHLY RECOMMENDED that our security products are installed by Armaplate approved fitters who have had specific training in the correct methods. More information available on our website www.arnaplate.com TM

CAUTION

Double-check to make sure that you have the right kit for the van you are working on BEFORE proceeding with your installation. If you are in any doubt, please ring 0845 838 0700.

This kit will also fit a Peugeot Expert and Toyota ProAce of the same year, and the updated Vauxhall Vivaro from 2019 onwards.

APHL27



Not suitable for a glazed door!

CYLINDER POSITION

Fig.3

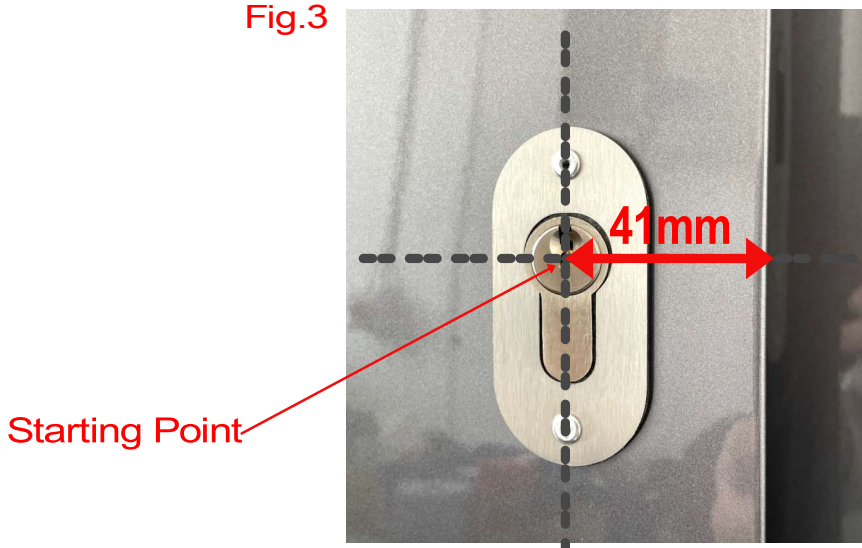

NOTE: Measurement applies to both offside and nearside doors

STRIKE BRACKET INSTALLATION

- Secure Lockcase in position.
- Apply masking tape to the Strike-Area.
- With the door fully closed, assess the hook-bolt position. Mark the tip of the hook with paint
- Mark the top of the receiver bracket aperture approx 3mm above the paint mark.
- When the Hook will lock through the aperture hole, hold the Bracket in place with Masking Tape and carefully close the door and check the locking. **Note you can check this from inside the van if you temporarily pull the rubber seal away.**
- When satisfied that you've got the Bracket position right, mark the 5mm rivet holes and drill.
- Treat all bare metal with automotive WAXOYL or similar.

Fig.4

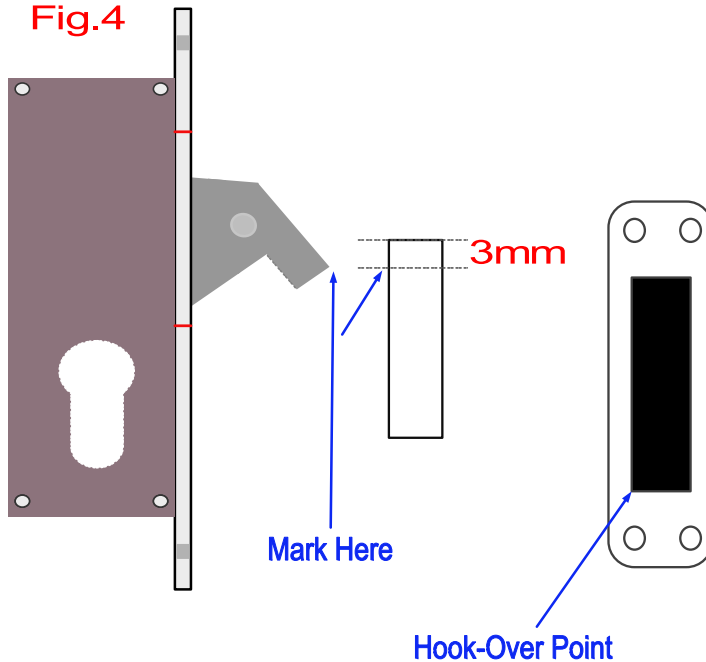

ESCUTCHEON PLATE

Slide the escutcheon plate over the cylinder and mark the two fixing hole. Drill 2 x 3.25mm holes as shown in Fig.3. Secure the plate with the supplied Dome Head Rivets.

NOTE: Treat all cut edges with rust-inhibitor!

Armaplate UK Ltd have taken great care to ensure the accuracy of all the information contained within these data sheets and guides, but we accept no responsibility for any errors in text, drawings or other sources of information relating to the installation of our products. It is the responsibility of the person carrying out the installation to make sure that he/she has all the necessary equipment, tools, dimensions, instructions and knowledge before beginning the work. Under no circumstances should the fitter make any alterations or drill holes in the vehicle's bodywork without being completely sure that the security product supplied is the correct one for the Make, Model, Year, Configuration of the van, noting that some products for example will not fit a van if glass windows are present. It is HIGHLY RECOMMENDED that our security products are installed by Armaplate approved fitters who have had specific training in the correct methods. More information available on our website www.arnaplate.com TM

CAUTION

Double-check to make sure that you have the right kit for the van you are working on BEFORE proceeding with your installation. If you are in any doubt, please ring 0845 838 0700.

This kit will also fit a Peugeot Expert and Toyota ProAce of the same year, and the updated Vauxhall Vivaro from 2019 onwards.

APHL29

Not suitable for a glazed door!



FITTING THE LOCKCASE

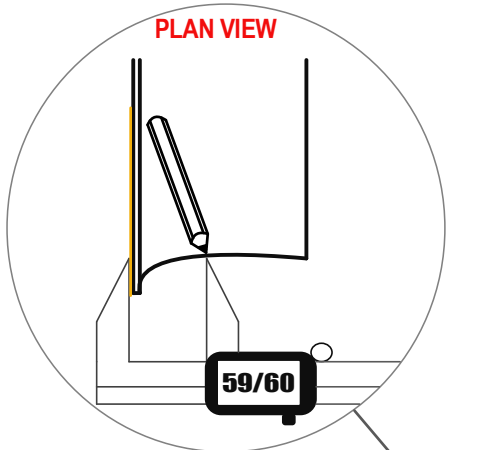

Protect paintwork by Applying Masking Tape
Use a Vernier Gauge to help mark out the dimensions of the aperture to be cut out

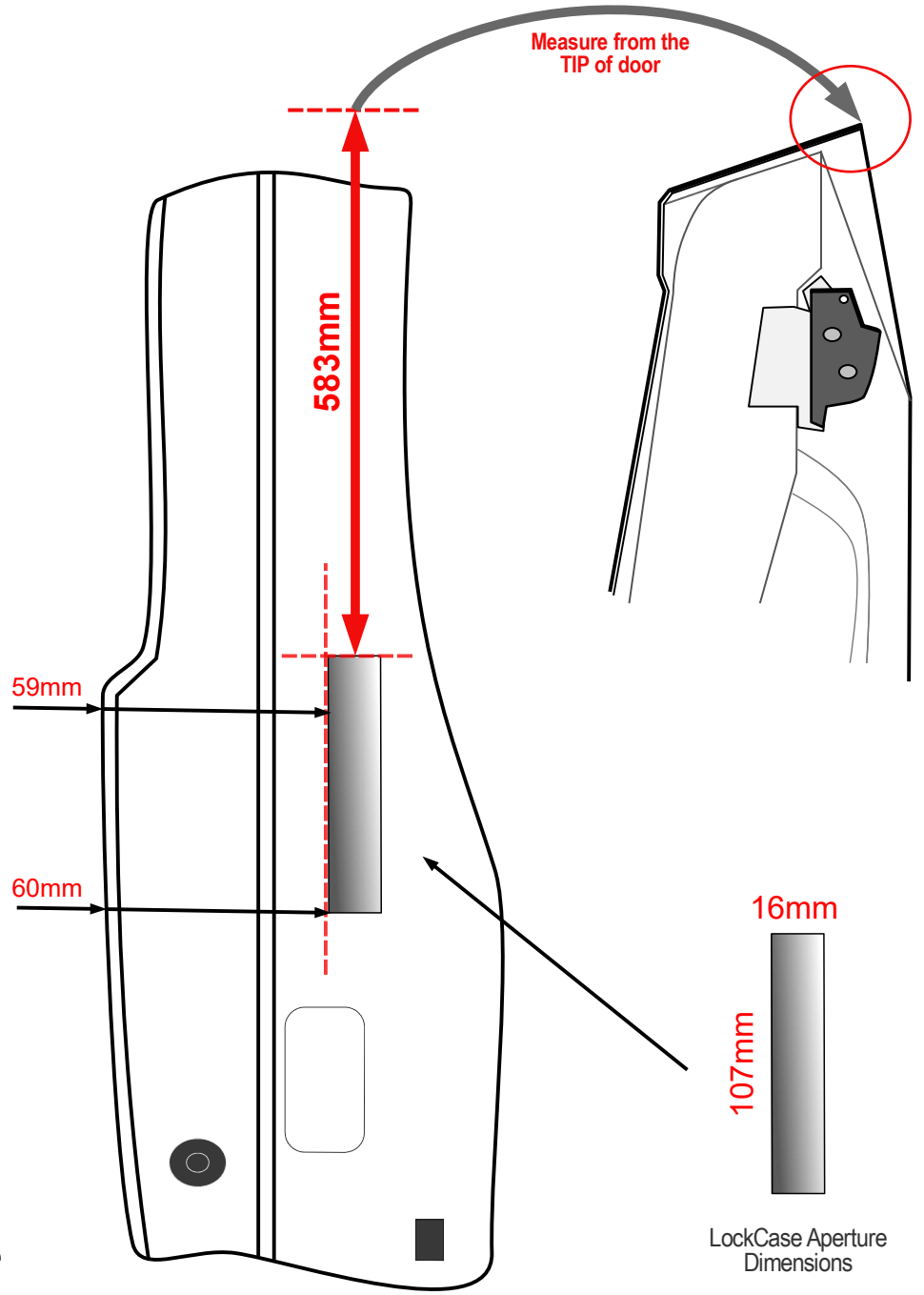

NOTE: DO NOT secure the LockCase until the hook clearance has been checked (see page 2).

NOTE: Treat all cut edges with rust-inhibitor!

Armaplate UK Ltd have taken great care to ensure the accuracy of all the information contained within these data sheets and guides, but we accept no responsibility for any errors in text, drawings or other sources of information relating to the installation of our products. It is the responsibility of the person carrying out the installation to make sure that he/she has all the necessary equipment, tools, dimensions, instructions and knowledge before beginning the work. Under no circumstances should the fitter make any alterations or drill holes in the vehicle's bodywork without being completely sure that the security product supplied is the correct one for the Make, Model, Year, Configuration of the van, noting that some products for example will not fit a van if glass windows are present. It is HIGHLY RECOMMENDED that our security products are installed by Armaplate approved fitters who have had specific training in the correct methods. More information available on our website www.arnaplate.com TM

CAUTION

Double-check to make sure that you have the right kit for the van you are working on BEFORE proceeding with your installation. If you are in any doubt, please ring 0845 838 0700.

This kit will also fit a Peugeot Expert and Toyota ProAce of the same year, and the updated Vauxhall Vivaro from 2019 onwards.

APHL29

Not suitable for a glazed door!



CYLINDER POSITION Fig.1

Starting Point

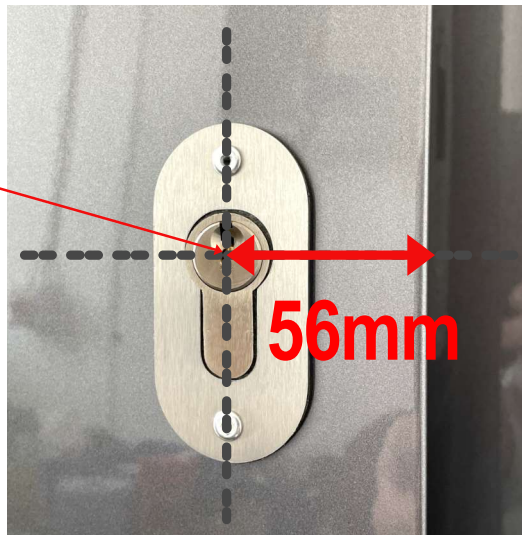

NOTE: the cylinder will come through at a steep angle. That is normal on this door.

Fig.2

Hook must rest on the edge of this return

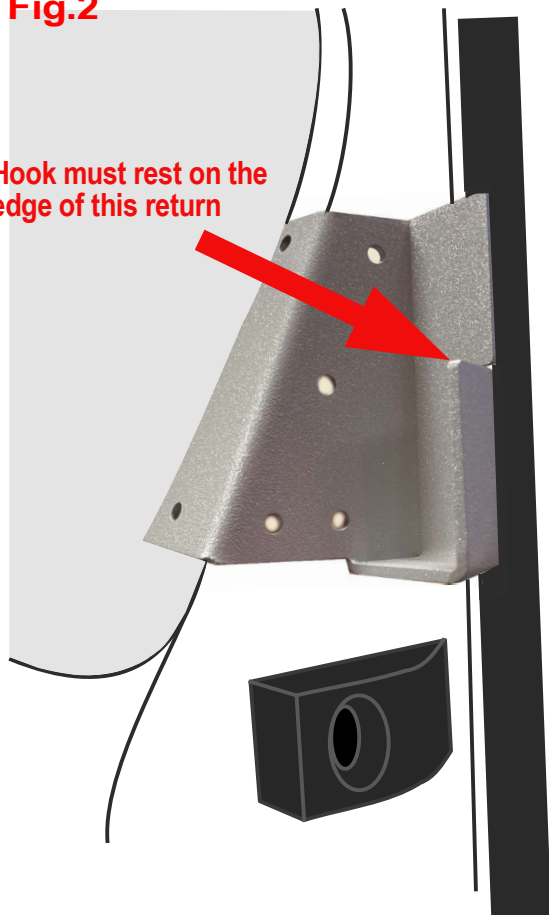

STRIKE BRACKET

DO NOT secure the LockCase until the Strike Bracket clearance has been checked.

The clearance should be checked from inside the van. Temporarily hold the bracket in place with Masking Tape. If more clearance is required, adjust the LockCase aperture.

With the Bracket temporarily in place, position the inside of the HOOK so that it just about rests over the return of the bracket (as indicated in the image on the left).

When you are satisfied that the lock operates correctly, drill and secure the Bracket using the supplied 5mm Dome Head rivets.

Secure the LockCase with the supplied 5mm CSK rivets.

Finally, fit the Escutcheon plate using the supplied 3.5mm rivets.

NOTE: Treat all cut edges with rust-inhibitor!

Armaplate UK Ltd have taken great care to ensure the accuracy of all the information contained within these data sheets and guides, but we accept no responsibility for any errors in text, drawings or other sources of information relating to the installation of our products. It is the responsibility of the person carrying out the installation to make sure that he/she has all the necessary equipment, tools, dimensions, instructions and knowledge before beginning the work. Under no circumstances should the fitter make any alterations or drill holes in the vehicle's bodywork without being completely sure that the security product supplied is the correct one for the Make, Model, Year, Configuration of the van, noting that some products for example will not fit a van if glass windows are present. It is HIGHLY RECOMMENDED that our security products are installed by Armaplate approved fitters who have had specific training in the correct methods. More information available on our website www.arnaplate.com TM

